

APPLIED ELECTRICITY 2

1. GENERAL COMMENTS

The standard of the paper was comparable to that of the previous years.

Candidates' performance was an improvement over the previous year.

2. SUMMARY OF CANDIDATES' STRENGTHS

Candidates' strengths were noted in these areas:

- (1) Definition of an insulator and stating properties of a good insulator;
- (2) Drawing a circuit diagram illustrating a PN junction diode connected in a reverse biased mode;
- (3) Stating applications of a PN junction diode.

3. SUMMARY OF CANDIDATES' WEAKNESSES

Candidates showed lack of in-depth knowledge in the following areas:

- (1) Drawing layout diagrams of radial and ring wiring systems;
- (2) Drawing and labelling the input-output (I-V) characteristics of a PN junction diode;
- (3) Calculating the feedback ratio and loop gain of a non-inverting operational amplifier (op-amp);
- (4) Application of Ohm's law to solve basic electrical problems.

4. SUGGESTED REMEDIES

- (1) Teachers should effectively teach students the techniques in responding to rubrics.
- (2) Teachers should endeavour to complete the syllabus to adequately prepare candidates for the examination.
- (3) Efforts must be made to take students on visits to industries, power stations, radio and television stations.

5. DETAILED COMMENTS

QUESTION 1

- (a) (i) Define insulator.
(ii) State two properties of a good insulator.
- (b)

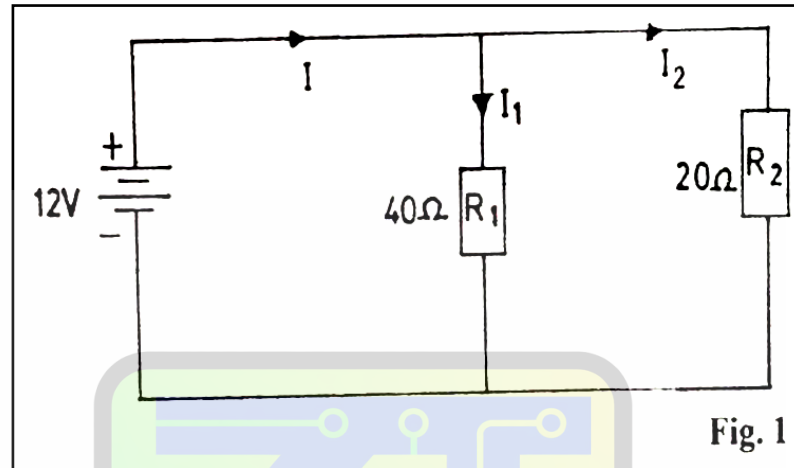

Fig. 1 is a circuit diagram. Using the diagram, calculate the:

- (i) current (I_1) flowing through resistor R_1 ;
(ii) current (I) flowing through the circuit.
- (a) A very popular and well answered question by majority of the candidates.
(b) A few candidates could not apply Ohm's law or Kirchhoff's law to the network in Figure 1 to obtain the required values of current.

QUESTION 2

Smart Learning Tools

A coil of 8Ω resistance draws a current of $12.25A$ when connected across a $240V$, $50Hz$ a.c. supply. Calculate the:

- (a) impedance of the circuit;
(b) inductive reactance;
(c) inductance of the coil.

A popular and fairly answered question. Some candidates could not arrive at the correct answers for the impedance (Z), inductive reactance (X_L) and inductance (L) of the coil even though they quoted the correct formulae as follows;

$$(Z) = \frac{V}{I} \quad , \quad X_L = \sqrt{Z^2 - R^2} \quad \text{and}$$
$$L = \frac{X_L}{2\pi f} \quad ; \quad \text{since } X_L = 2\pi fL$$

QUESTION 3

Draw layout diagrams of radial and ring wiring systems using four 13 A socket outlets, a fuse and an a.c. supply.

A poorly answered question.

The majority of the candidates could not draw layout diagrams of radial and ring wiring systems as expected.

The instruction to use four socket outlets was also not adhered to.

QUESTION 4

- (a) Explain two methods of exciting a.c. generators.**
(b) Calculate the frequency of the e.m.f. produced by an a.c. generator having 4 poles rotating at a speed of 3600 revolutions per minute.

- (a) The majority of the candidates stated the two methods of exciting a.c. generators but failed to explain the methods as demanded by the question.

Candidates were expected to answer as follows:

- Self - Excited A.C. Generator: - The magnetic field of the main poles is excited by a current supplied to the windings of the main poles from the armature winding.
- Separately Excited A.C. Generator: -The magnetic field of the main poles is excited by a current supplied to the windings of the main poles from an external source.

Smart Learning Tools

QUESTION 5

- (a) Draw and label the input-output (I – V) characteristics of a PN junction diode.**
(b) Draw the circuit diagram to illustrate a PN junction diode connected in a reverse biased mode.
(c) State three applications of a PN junction diode.

- (a) Sketching and labelling the (I-V) characteristics of a PN junction diode was poorly executed by majority of the candidates.
(b) The majority of the candidates answered this question very well.
(c) Most of the candidates stated the applications of the PN junction diode without any difficulty.

QUESTION 6

(a) State three methods of electron emission.

(b) (i) Draw and label a triode valve.

(ii) State the function of each electrode labelled in (b)(i).

(a) This was generally well answered.

(b) (i) The response to this question was very poor.

A well labelled diagram of a triode valve is shown below.

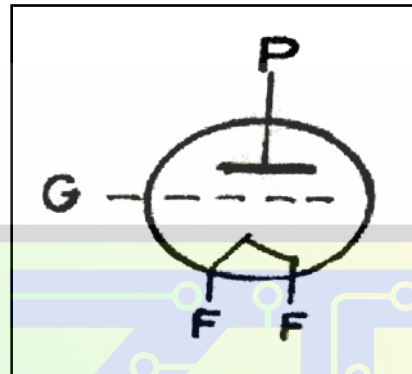

Filament serving as cathode

P - Anode/Plate

F- Filament/Cathode

G - Grid

Or

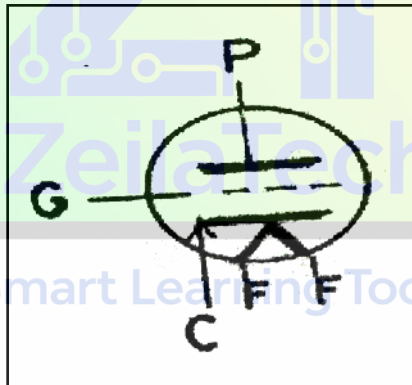

Triode with separated cathode and filament

(ii) The function of the electrodes as labelled in (b)(i) is given as

- Cathode: releases the electrons;
- Anode: attracts the electrons;
- Grid: controls the electrons emitted from the cathode.

QUESTION 7

- (a) Explain the term Noise as it relates to amplifiers.
- (b) A non-inverting operational amplifier (op – amp) has $R_i = 1 \text{ k}\Omega$, $R_f = 99 \text{ k}\Omega$ and open loop gain $A = 500,000$. Calculate
- feedback ratio (β);
 - loop gain.
- (c) State the formula for computing:
- voltage gain;
 - current gain;
 - power gain in amplifiers.

A very unpopular question.

- (a) The few candidates who attempted question seven managed to explain the term Noise as applied to amplifiers quite satisfactorily.
- (b) The majority of the candidates could not quote the formulae well to arrive at the correct answers even though all relevant parameters had been given.
- The formulae for calculating the feedback ration (β) = $\frac{R_i}{R_i + R_f}$ and
- The loop gain = βA
- (c) A considerable number of candidates provided good responses to this question.

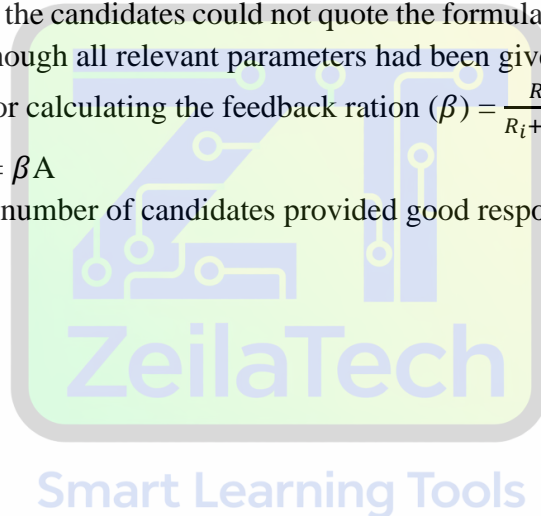

APPLIED ELECTRICITY 3

1. GENERAL COMMENTS

The standard of the paper compared favourably to that of the previous years. Candidates' performance was generally satisfactory.

2. SUMMARY OF CANDIDATES' STRENGTHS

- (1) The majority of the candidates understood the two experiments and were able to connect the circuit diagram.
- (2) Most of the candidates plotted good graphs.
- (3) Candidates used good scales in plotting their graphs.

3. SUMMARY OF CANDIDATES' WEAKNESSES

- (1) Candidates wasted time by copying the circuit diagrams.
- (2) Some candidates could not determine the slope of the graph.

1. SUGGESTED REMEDIES

- (1) Teachers should adequately cover the teaching syllabus.
- (2) Laboratories should be well equipped to enhance effective teaching and learning.
- (3) Teachers should give more practical exercises to candidates to improve upon their skills.

1. DETAILED COMMENTS

Candidates were provided with the following apparatus:

- One digital multimeter;**
- One variac (0-230V);**
- One 230V/12V transformer;**
- One voltmeter (0-40V);**
- One voltmeter (0-230V);**
- One rheostat, 11.5 Ω , 5A;**
- One ammeter (0-6000mA);**
- One ammeter (0-600mA);**
- Two single-pole switches;**
- Connecting wires;**
- A set of hand tools.**

QUESTION 1

Aim: To determine the turns ratio of a single-phase transformer.

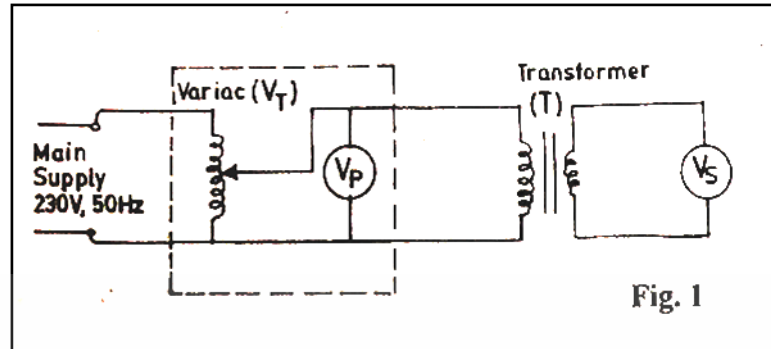

- Connect the circuit as shown in Fig. 1.
- Ask the supervisor to check the circuit connection.
- Copy Table 1 into your answer booklet.

Table 1

V_p (V)	0	10	20	30	40	50	60	70
V_s (V)								

- Set the variac (V_T) to 0V.
- Connect the variac to the main supply and switch on.
- Read and record the voltage value (V_s) in Table 1.
- Adjust the variac to read 10V on V_P and record the corresponding value of V_s .
- Repeat step (g) for the other values of V_P in Table 1.
- Plot a graph of V_p (V) on the vertical axis against V_s (V) on the horizontal axis.
- Determine the slope of the graph.
- From the slope of the graph in step (j) deduce the turns ratio of the transformer.

In experiment 1, candidates were to determine the turns ratio of a single-phase transformer.

The majority of the candidates were able to connect the circuit diagram correctly.

Most of the candidates who attempted this question were able to determine the slope of the graph and deduced the turns ratio of the transformer.

Candidates' performance was fair.

QUESTION 2

Aim: To determine the current ratio of a transformer.

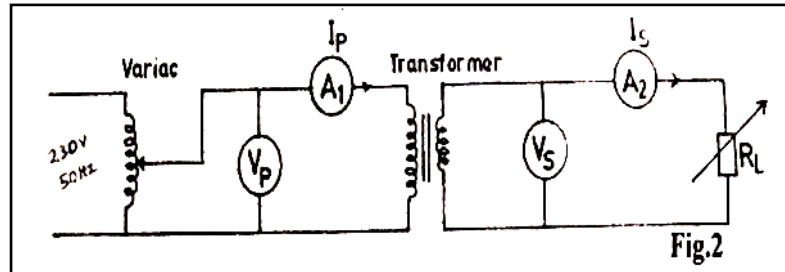

- Connect the circuit as shown in Fig. 2.
- Ask the supervisor to check the circuit connection.
- Copy Table 2 into your answer booklet.

V_p (V)	I_p (A)	I_s (A)
200	0.1	
200	0.2	
200	0.3	
200	0.4	
200	0.5	
200	0.6	

- Set the variac to 0V.
- Connect the variac to the main supply and switch on.
- Using the multimeter, set the load (R_L) to its maximum.
- Adjust the variac to give 200V on V_p . Maintain this voltage throughout the experiment.
- Vary the load (R_L) to indicate the current (I_p) of 0.1A on ammeter (A_1).
- Read and record in Table 2 the corresponding value of I_s on ammeter (A_2).
- Repeat steps (h) and (i) for the other values of current (I_p) in Table 2.
- Plot a graph of current (I_s) on the vertical axis against current (I_p) on the horizontal axis.
- Determine the slope of the graph.
- State the current ratio of the transformer.

In experiment 2, candidates were required to determine the current ratio of a transformer.

The majority of the candidates were able to connect the circuit diagram as required.

The majority of the candidates plotted the graph by selecting very good scales.

Some of the candidates wrongly read the calibrations of the analogue meter.

Most of the candidates were able to calculate the slope of the graph and determine the current ratio of the transformer.

Candidates' performance was quite satisfactory.

